

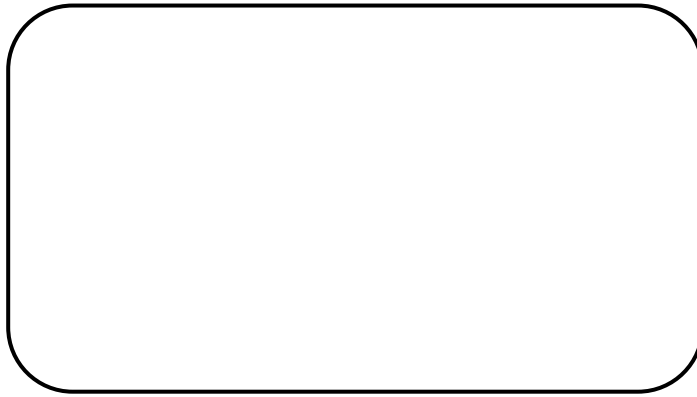

Translation of
Original User Manual



Local distributor & service partner:



Manufactured by:
GMV A/S
Industriparken 1
7182 Bredsten, Denmark
Denmark

Tel.: +45 7573 8247

www.gmvas.dk

Important!

- **Please read this user instructions carefully before use.**
- **Familiarise yourself with the running and lifting characteristics of the window robot, and**
- **also with its driving characteristics and how it behaves, so that you can use it safely, securely and efficiently.**
- **Please remember that you as the user are responsible for the correct use of the window robot without endangering other persons or property.**

Index

Overview and Safety

- 4 Description
- 5 Safety instructions
- 7 Operation and safety
- 9 Safety tests (before starting)

Use of Winlet 1000

- 10 Driving
- 11 Lifting and handling

Service/maintenance

- 15 Storage and lifting of the Winlet 1000
- 17 Servicing
- 17 Troubleshooting
- 17 Charging the batteries
- 19 Service/maintenance
- 22 Specifications
- 23 CE – EU declaration of conformity

Dear Customer

Thank you for choosing a GMV A/S product. We have more than 25 years of experience in the construction, manufacturing and other industries. We develop, produce and sell equipment for materials handling designed for industrial use.

Discover more on our webpage: www.gmvas.dk

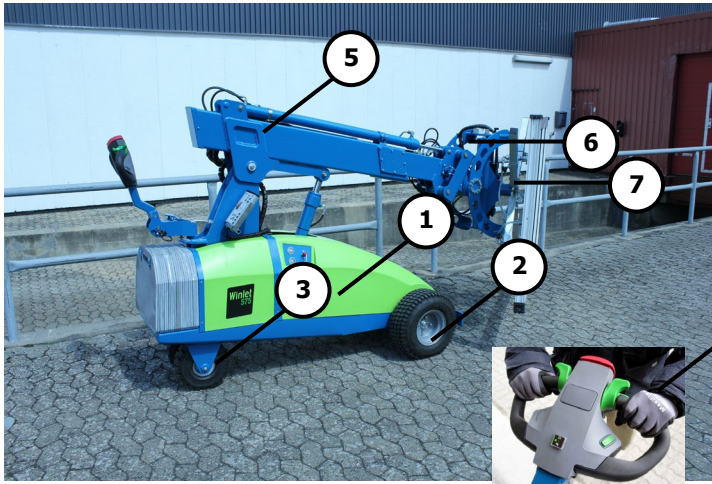

Description

Item Name

- 1 Protective screen
- 2 High traction, terrain-friendly wheels
- 3 Steering wheel
- 4 Operating handle/Tillerhead for running
- 5 Boom with telescopic arm
- 6 Lifting tower
- 7 Vacuum boom
- 8 Control panel

Description

The Winlet 1000 is a battery-powered window robot with a lifting capacity of 1000 kg. The window robot is made by GMV A/S to facilitate conveying and mounting of window elements or similar sealed items. Winlet 1000 can also be equipped with other specially designed lifting and handling attachments to allow the transport and handling of other types of heavy loads. Winlet 1000 is powered on the front axle with terrain-friendly wheels and has an advanced, electro-hydraulic system for the handling the loads to be lifted.

The Window robot is equipped with an integrated vacuum system as standard. Please contact us concerning your needs in relation to transporting items requiring special lifting and handling attachments.

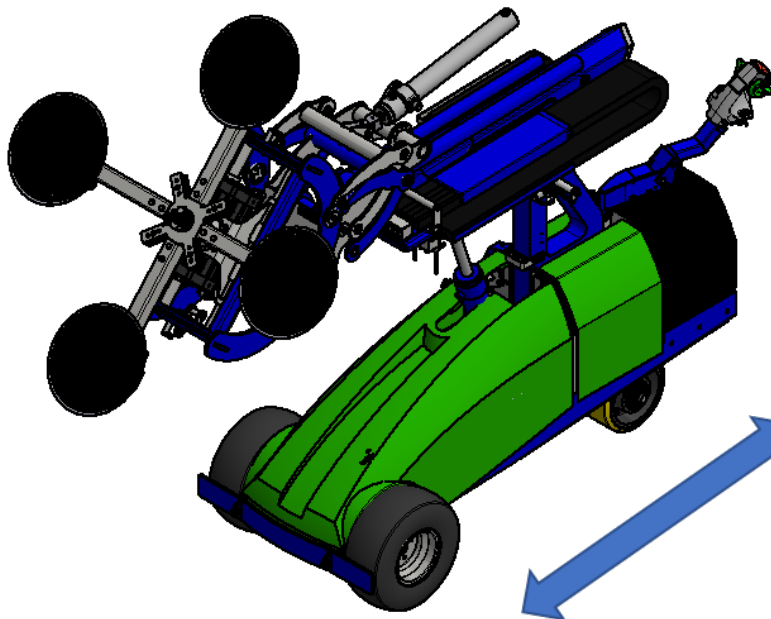

Driving direction for transport with or without load.

Preferred Driving Direction

Driving direction when picking up the cargo or placing of the cargo.

Secondary driving direction

Safety instructions

General

- The window robot must be used as described in these instructions and in accordance with the general safety regulations applicable in the workplace and in the country where the Winlet 1000 is used.
- Always wear steel-capped safety footwear when working with the Winlet 1000. Depending on the workplace and the type of load, a helmet and protective gloves may also be required.
- To prevent unauthorised personnel from using the window robot, never leave the key in the ignition.
- Never leave the Window Robot on an inclined surface. The truck may begin to roll even though it is equipped with a parking brake.
- Before use, check that the Winlet 1000 is not damaged in any way that could impair safety.
- Never use the Winlet 1000 when the battery indicator glows red, as this could ruin the battery. Instead, charge as described elsewhere in this manual.
- Never use or store the Winlet 1000 outdoors in wet weather. The machine is designed for use in the temperature range from -10°C to + 40°C.

Driving

- The user must be aware of his surroundings when using the window robot and must allow a generous safety margin in case unexpected situations arise.
- Plan your route and make sure it is unobstructed and negotiable. Avoid surfaces where there is a risk that the window robot could overturn or slide. Exercise great care at corners and junctions.
- To avoid danger of overturning, the window robot's right-hand wheel set must always be at the same level as its left-hand wheel set.
- Always drive with the load lowered. When driving without load, arm and head should also be positioned as low as possible. During transport of load - Always drive in the PREFERRED DRIVING DIRECTION. (See page 4)
- Remember that high speed in constricted spaces is a major safety risk.
- Never make sharp turns at high speed. Turning reduces the stability of the window robot.
- Only use the Winlet 1000 in locations with adequate lighting.
- Always keep both hands on the steering handle when manoeuvring.

Vacuum

- The Winlet 1000 is designed to transport and mount window elements and other sealed elements as well as other materials using the specialist equipment supplied.
- Always lift the item at its centre of gravity and in the middle; otherwise, the item may tear free from the suction plates.
- Only activate the vacuum function when the suction cups are placed on a sealed, dry, clean surface. Any other use can damage the vacuum system.

Lifting and handling

- The Winlet 1000 has moving parts which could give rise to a risk of crushing injuries; accordingly, when lifting and lowering loads, it is important to ensure no one is in the hazard zone where crushing could occur.
- Never lift an item until a sufficient vacuum has been achieved. If the vacuum level diminishes, set the item down immediately.
- Exercise great care when lifting and handling lifted items, as sudden movements or jolts can cause the item to break away from the suction cups.
- Be particularly aware of the capacity limitations of the machine (as stated elsewhere in this manual). The machine's capacity is reduced when items are handled with the lifting arm extended or when lifting at the side of the machine. Pay attention to the warning signals from the machine when maximum capacity is reached.

Driving direction for transport with or without load.

Preferred Driving Direction



Driving direction when picking up the cargo or placing of the cargo.

Secondary driving direction

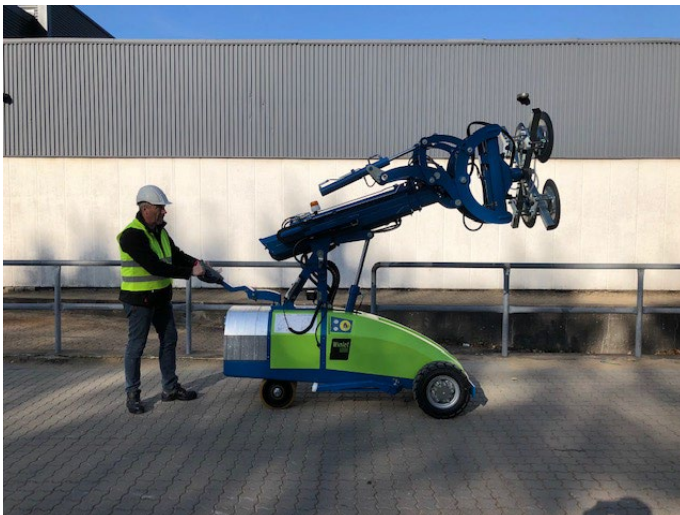

Operation and safety

Safety functions when driving

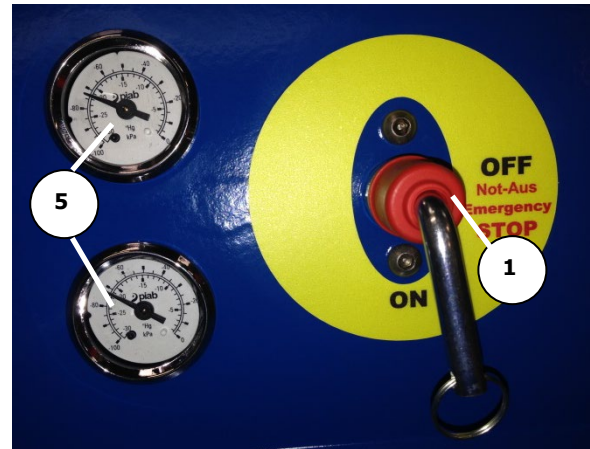
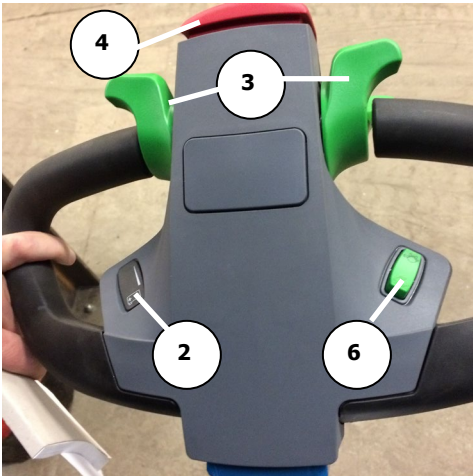

Description

Item Name

- 1 Power key switch/EMERGENCY STOP
- 2 Battery indicator
- 3 Drive direction/speed regulator
- 4 Safety cut-out switch (stomach switch)
- 5 Vacuum meter
- 6 Hi-speed / crawl switch

Winlet 1000 is equipped with a standard type of manoeuvring handle. The handle incorporates several safety features.

- Safety switch ("stomach switch"); when activated, stops the movement of the window robot. Once the movement has stopped, the window robot moves in the direction: Secondary driving direction (see page 6) to avoid risk of crushing.
- Tiller switch, which ensures that all driving functions are interrupted when the Tiller head is placed in the top position.

Winlet 1000 is equipped with a standard manoeuvring handle. The power switch also acts as EMERGENCY STOP. As soon as the switch is turned to the "OFF" position, the power supply to all machine functions is interrupted. The key switch is spring loaded so that on activation of the EMERGENCY STOP, it remains in OFF. Both the drive with hydraulic cylinders or the drive motor then come to an immediate halt. On activation of the emergency stop, there is ALWAYS negative pressure in the suction head - special vigilance is therefore required as the vacuum pump also loses power after an emergency stop. Both vacuum circuits are equipped with separate vacuum tanks to ensure sufficient vacuum for a min. of 5 minutes provided that the system is free of leaks. The actual vacuum level in the suction cups can always be read on the 2 vacuum meters. When the vacuum level is 60% or more, the machine is at full lift capacity.

Safety functions when lifting and handling



Description PSAC Panel

Item Designation

- 1 Choice of hydraulic cylinder
- 2 LED indicator – cylinder
- 3 Activation of vacuum
- 4 LED indicator – vacuum level
- 5 LED indicator – overload
- 6 LED indicator – on/off
(Blinks at low battery level)
- 7 Direction & speed regulator – cylinders.
- 8 LED indicator – “Out of level”
- 9 Emergency stop

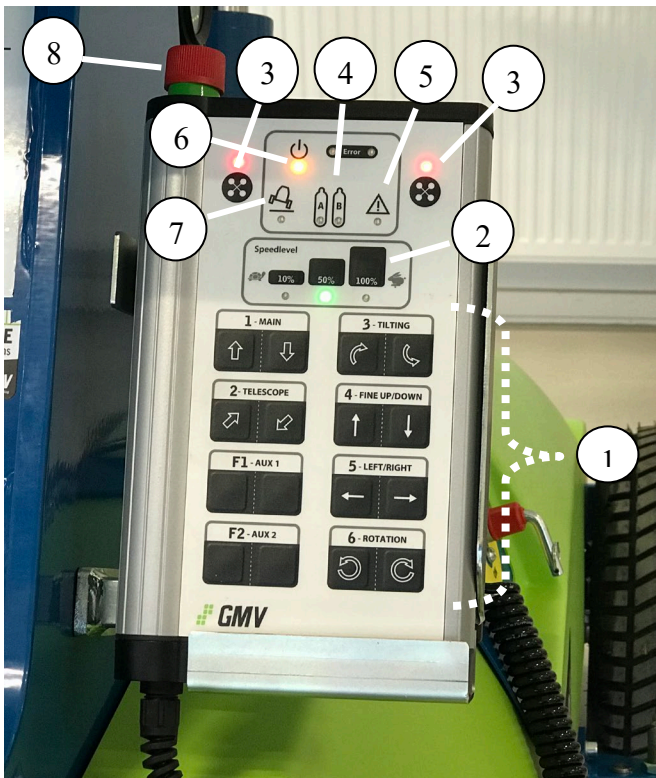

Description MAC Panel

Item Designation

- 1 Push to use hydraulic cylinder
- 2 LED indicator – speed regulator
- 3 Activation of vacuum
- 4 LED indicator – vacuum level
- 5 LED indicator – overload
- 6 LED indicator – on/off
(Blinks at low battery level)
- 7 LED indicator – “Out of level”
- 8 Emergency stop

The Winlet 1000 is equipped with an operating panel from which all vacuum and hydraulic functions are controlled. The integrated safety functions are:

- 2-button safety operation of the machine's vacuum system. Both buttons must be activated at once either to pick up or to set down a load.
- The double-circuit vacuum system of the machine is monitored by two vacuum regulators which, via LED lamps, indicate if the vacuum is insufficient for safe lifting.
- LED lamps show which cylinder is active.
- LED lamp which indicates that the machine's front wheels are not in the same level
- Intelligent overload protection shows when the machine reaches the limits of its capacity.

Note that the machine's stability is impaired by lifting loads at the side of the machine and that these risks are **not** monitored by the machine overload monitoring. Always use the outrigger when handling loads at the side of the machine. **Always exercise particular care when handling loads at the side of the machine and, as the operator, always consider whether safety is assured and ensure that the capacity of the machine is not exceeded.**

Safety test (before driving or lifting)

The window robot must be safety tested every day before use. This test must be carried out without load.

Important! If any of the items do not pass the safety test, the machine may not be used!

- Carry out a visual inspection to ensure that the mechanical parts of the window robots are not worn or damaged to such an extent that the safety of the machine is compromised.
- Hold the operating arm down in the normal position and drive the Winlet 1000 back and forth. Move the operating arm, without load, to the top position and try driving the machine forwards and backwards. This should not be possible.
- Drive the Winlet 1000 towards you and depress the safety switch on the handle. The machine must stop immediately and move away in the opposite direction.
Important! This test must be carried out in an open space where there is no risk of your being crushed between the window robot and any objects or walls.
- Drive the Winlet 1000 away from you and release the operating arm. The spring pressure in the operating arm must take the operating arm to the no-load top position, after which the machine must stop at approximately 0.5 m and the truck functions must not be usable until the operating handle is back down in the operating position.
- Check the window robot vacuum system for leaks:
Leak testing procedure
Place all suction cups on a level, dry and airtight surface (e.g. a window). Start the Winlet 1000 at the on/off button and wait until the red lamps go out on the operating panel. Now activate the vacuum by actuating both buttons on the operating panel at the same time. Both vacuum meters now show the current vacuum in each vacuum circuit. Once a full vacuum has been achieved in both circuits (a vacuum level of approximately 75%), turn the Winlet 1000 off again at the on/off button. Now look at both vacuum meters; the vacuum level must not drop more than 10% in the course of 5 minutes.
If the vacuum loss is greater than 10% in 5 minutes, check all hose connections and tighten any connections as required. Also check the condition of the suction pads. The seals must not show any signs of scratches.
- The arm is shot out approx. 0.8 m, the machine must now only run in "turtle" mode.
- The arm is retracted and above the horizontal, the machine must now only run in "turtle" mode.

Driving

Forward/reverse

The speed is infinitely adjustable and is adjusted by turning the regulator to a greater or lesser degree.

- Keep the operating arm in the normal position and then turn the drive direction and speed regulator to the desired position. Release the regulator to stop the machine.
- See page 4 for PREFERRED and SECONDARY driving direction
- If the arm is raised above the horizontal or shot approx. 0.7m out, or if the Winlet 1000 is approaching its max. load, the driving speed will automatically switch to "turtle". The Winlet 1000 can during driving change from "hare" to "turtle" if it underway detects that the given limits are exceeded. Switch from "turtle" to "hare" requires that the Winlet 1000 is stationary, and the arm manipulated so it is under the given limits.
- When driving with load / topics should these be positioned as close to the Winlet 1000 and as low as possible.

Braking

- When the speed regulator is released, the window robot brakes and stops. Releasing the speed regulator slowly can produce gentle braking. This is the normal braking method.
- When the operating arm is released, the transport truck stops suddenly, and the parking brake kicks in. This function is only intended to be used in an emergency.
Important! To maximise the service life of the Winlet 1000, it is recommended to release the speed regulator first, and only to release the operating arm once the machine has stopped.

Manual pull/push of the machine in the event of breakdown of the electrical drive

The electrically powered drive shaft, which powers the front wheelset of the machine, can be disengaged in the brake. This is useful in the event of a breakdown of the machine.

- Remove the green protective screen.
- Press the "push" button on the PCB.
- Make sure the power steering for operating the machine is working (turn on the driver's head and check that the steer wheel rotates) so that the brake is not released without steering control.

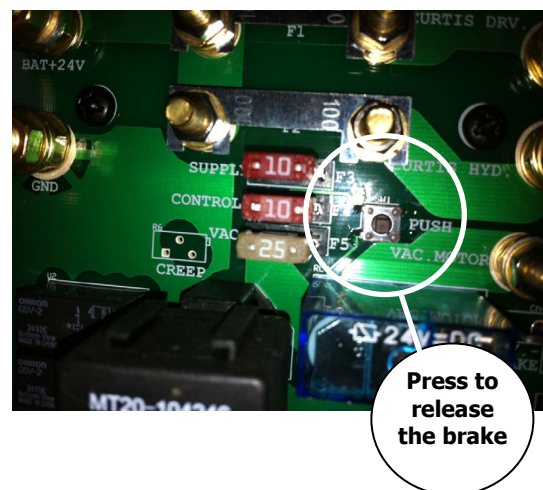

Lifting and handling

Vacuum lift

The Winlet 1000 is equipped with an integrated **double circuit** vacuum system with intelligent vacuum monitoring, which gives an alarm to indicate insufficient vacuum level. The vacuum pump is equipped with Power Save, to save the batteries when there is sufficient vacuum.

Using the vacuum function

Start the Winlet 1000 with the on/off button. Press both buttons for the vacuum function on the operating panel and wait a moment until both red LED lamps go out. During this time, a vacuum of at least 60% has been created in the vacuum system.

Picking up a load

Place the suction plates on the item. Press both buttons at the same time on the operating panel. The item is firmly held by suction once both vacuum meters show more than 60% and the red lamps have gone out; only then can lifting and transporting proceed!

- ! Make sure the vacuum level is above 60% in both circuits.
- ! Always lift the item at its centre of gravity and in the middle; otherwise, the item may tear free from the suction plates.

Moving a load

After picking up the item by suction power, move the item to the desired position by driving the Winlet 1000.

Pay attention to the following points:

- ! No persons and/or objects may be present in the working area.
Danger of collision damage/injury!
- ! No-one may be present under a raised load!
Danger from falling load!
- ! If the vacuum level in only one of the 2 vacuum circuits drops below 60%, set the load down **immediately!**
- ! If one of the red lamps lights up, set the load down **immediately!**

Setting down the load.

Convey the lifted item to the desired place and set it down. When the load has been placed securely, press both buttons on the operating panel simultaneously. Air can now flow to the suction pads. The load is released immediately. A new task can now be carried out.

- ! Make sure the load is placed securely and that it cannot slide after being set down!

Manipulating load (use of hydraulic cylinders)

The Winlet 1000 is equipped with an electro-hydraulic system which makes it possible to move the lifting arm of the machine in 6 different axes:

1. Rotation
2. Lateral displacement
3. Main cylinder, which positions the item roughly in the vertical position.
4. Telescopic cylinder, which moves the item forward along the longitudinal axis of the machine.
5. Tilting cylinder, which moves items from a horizontal floor – to a horizontal ceiling (180 degrees).
6. Fine-adjustment cylinder, which moves the item in a 100% horizontal direction.

Using the multi-movable front

The front of Winlet 1000 can also be rotated at the side of the machine and thus facilitate access through doors and narrow openings.

When the front has been brought to the desired position, it must always be relocked.

! Be aware that it is possible to damage the head when it is turned on the side of the machine if the operator does not pay attention during operation. Therefore, it is important that the operators familiarize themselves with how the machine works when the head is turned to the side. This should be done before handling any glass or windows.

Use of hydraulic cylinders

Press the desired cylinder on the operating panel. An LED lamp will now show the selected cylinder. The cylinder can then be moved in the desired direction at the desired speed by engaging the direction and speed regulator.

Pay attention to the following points:

- ! No persons and/or objects may be present in the working area.
Danger of collision damage/injury!
- ! No-one may be present under a raised load!
Danger of falling loads!
- ! If the vacuum level in only one of the 2 vacuum circuits drops below 60%, set the load down **immediately!**
- ! If one of the red lamps lights up, set the load down **immediately!**

Important! Be aware that the capacity of the machine is reduced when using the hydraulic cylinders.

Maximum length of Beam -Capacity

WLL on vacuum beam

Capacity of the vacuum front is depending on position of the cups. The chart shows capacity depending on distance from cup (centre of cup) to attachment of beam.

Length L mm	Capacity kg
500	1.000
550	1.000
600	1.000
650	944
700	877
750	818
800	767
850	722
900	682
950	646
1.000	614
1.050	584
1.100	558

- A: Vacuum circuit 1
- B: Vacuum circuit 2

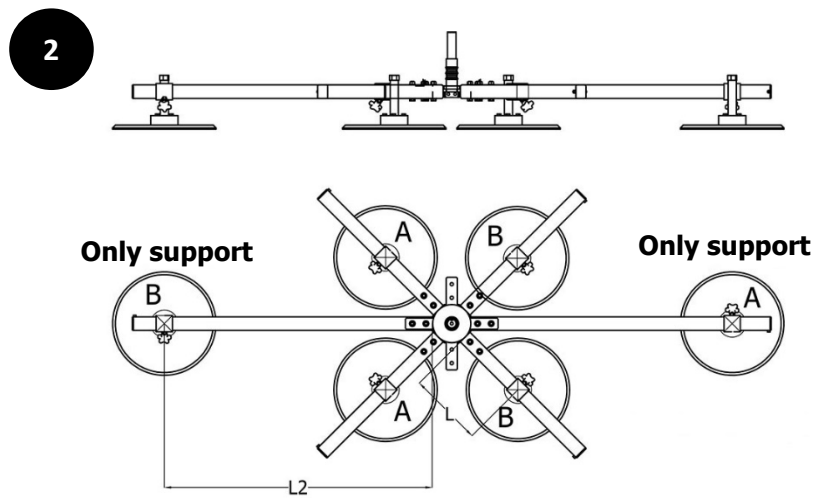
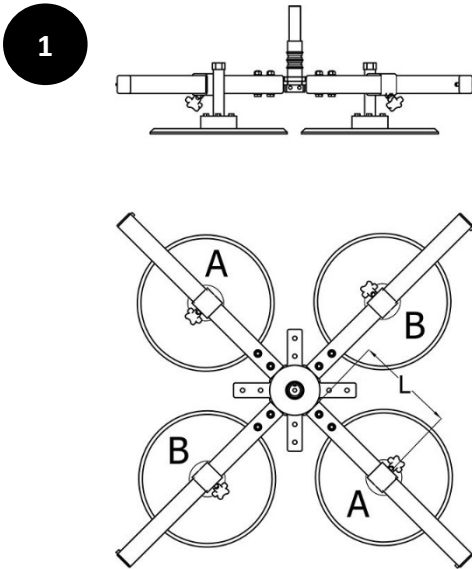

pic. 2
Cups in distance L2 is only extra support and does not add to WL

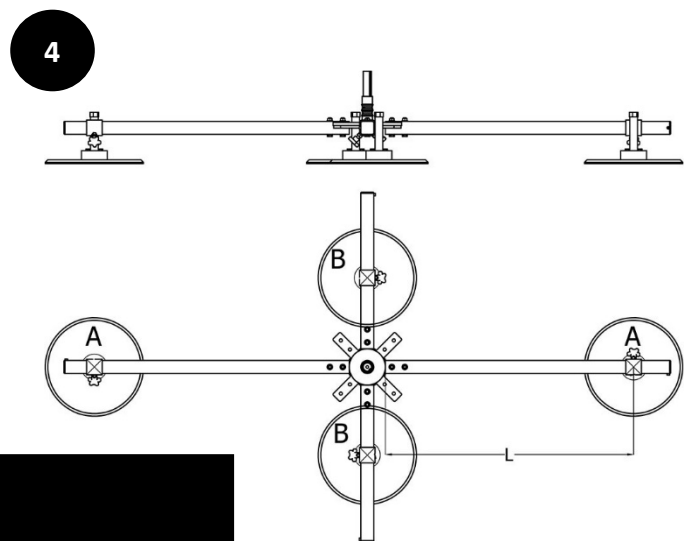
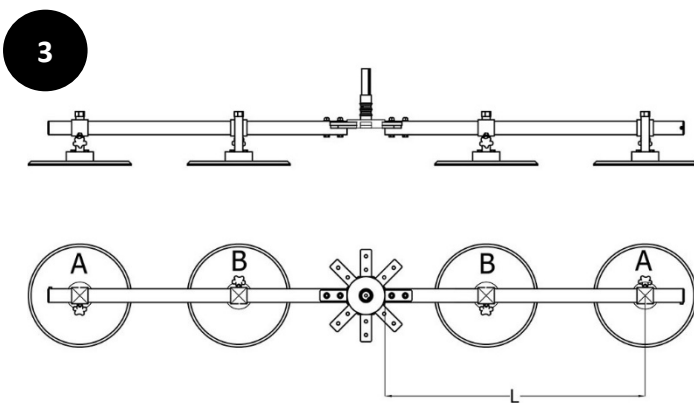

pic. 3 + 4
Length on LONGEST arm is determining WLL

"Gyro function"

Winlet 1000 is equipped with a "gyro function" with a sensor which holds the front in a given vertical position. When the feature is enabled, there is an automatic adjustment at the front to ensure that this remains the same angle when the master cylinder is used (cylinder 3). Gyro is activated as follows:

- **Press the cylinder 5 button and hold for 2 seconds. The LED lamp for cylinder 5 will now flash and LED lamp for cylinder 3 will light permanently. The Winlet 1000 will now hold the item at the desired angle.**
- **To deactivate the Gyro, the button for cylinder 5 is pressed until the LED lamp stops flashing.**

Gyro is most accurate with load in the front and at an angle of +/- 45 degrees from the vertical.

WINLET 1000 **MAX. LOAD** kg.

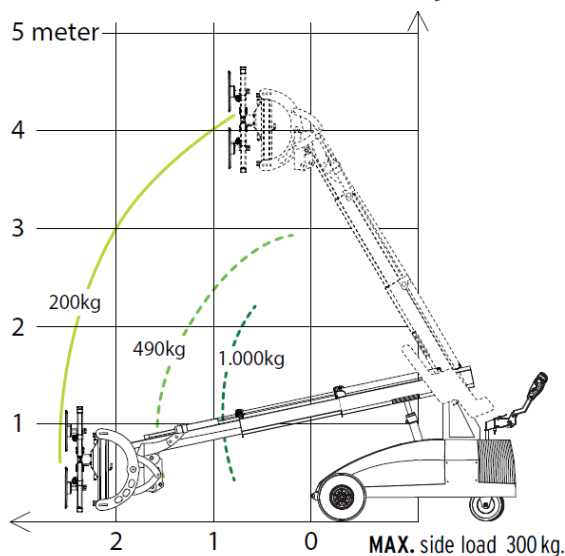

WINLET 1000 **MAX. LOAD/REACH** kg.

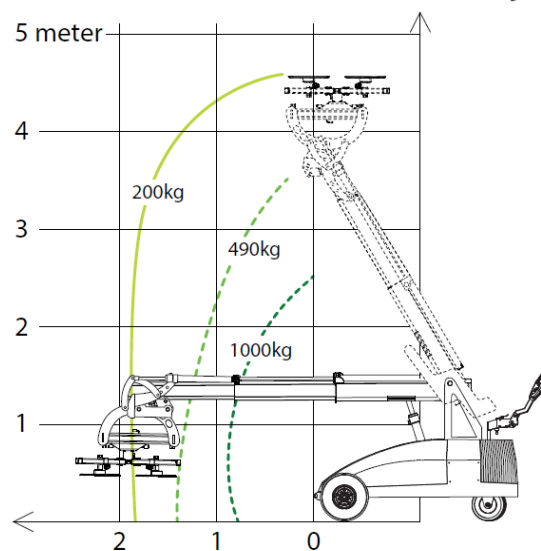

The stated values are for reference. And based on a 100% level surface.

The Winlet 1000 is equipped with load monitoring, whereby a red lamp flashes on the operating panel when approaching the max. capacity in each position. At this warning, all cylinders must be retracted. If you continue running the cylinders "outwards", the warning lamp will remain on constantly and there is a risk of the machine overturning. Now you can only use features that reduce loading and minimize the risk of overturning.

! It is always the responsibility of the operator to ensure that the machines used within the capacity limits. This also applies if the overload system is inoperative.

! Note: The safety function uses oil pressure gauges, which measure changes in the pressure of the master cylinder (cylinder 3). This means that use of the extension cylinder (cylinder 4) may result in situations in which the safety function may be "delayed". The user must therefore pay extra attention to the machine's capacity limits when the cylinder 4 is used. To ensure that the overload function operates, the user must always ensure that the cylinder 3 is activated within other hydraulic functions are used.

Note that using the machine on non-level terrain/driving surface impairs the stability of the machine, and that these risks are **not** monitored by the machine's overload monitoring system. Always use the support wheel if the machine is not being operated on level terrain/driving surface. **Always exercise particular care where the machine is being used on non-level terrain/driving surface, and, as the operator, always consider whether safety is assured and ensure that the capacity of the machine is not exceeded.**

Transport of machine (driving)

The machine must not drive crossways to a slope with an inclination of 7 degrees to the longitudinal axis of the machine. This incurs the **risk of tipping. This risk is not countered by the machine's safety system.**

Out-of-level alarm

If the Winlet 1000 is used on unlevel ground (both front wheels in the same level) a LED lamp will flash on the control panel and an acoustic signal will sound.

Using the multi-movable front

The machine's front door is locked against movement on the side of the machine. If it is desired to move the front to the side of the machine, the two locks (top and bottom of the front) are unlocked.

When the front has been brought to the desired position, it must always be relocked.

Influence of wind on the Winlet 1000

- Machine may not be used when exposed to wind speeds exceeding 10 m/s.

Use in wind speeds in excess of 10 m/s is associated with a great risk of tipping.

Storage and lifting of Winlet 1000

- After use, check the charging level of the batteries via the battery indicator, and recharge as required. See below concerning instructions regarding recharging.
- Never use the Winlet 1000 when the battery indicator glows red.

Important! Batteries stored for a prolonged period must have a maintenance charge (be fully charged) to avoid damage to the batteries.

- Turn off the window robot. To do so, turn the ignition key/press the off button.

Important!

When storing for an extended period, turn off the machine to avoid damaging the batteries. This is because there is always a residual current flow if the ignition is on.

- The Winlet 1000 must only be raised by the attachment points are shown on the pictures: 1. front by sprockets and 2. under counterweight.
- Lifted with a lifting sling supplied as an accessory for the Winlet 1000.
- The lifting sling is attached with M12 X 130 mm in the same bolt holes as used for the lashing lugs.
- Attachment points used for lashing of the machine during transport.
- No strain must be applied to the arms during transport - this will cause damage to the machine.

Sling attachment point at counterweight:

Sling attachment points at the drive wheel:



Lashing during transport - Winlet 1000

Below is illustration and description of safe lashing of Winlet 1000 during transport on truck. Note that these guidelines are in accordance with International rules for lashing according to **EN 12195-1**.

Arrow is indicating the preferred direction of travel.

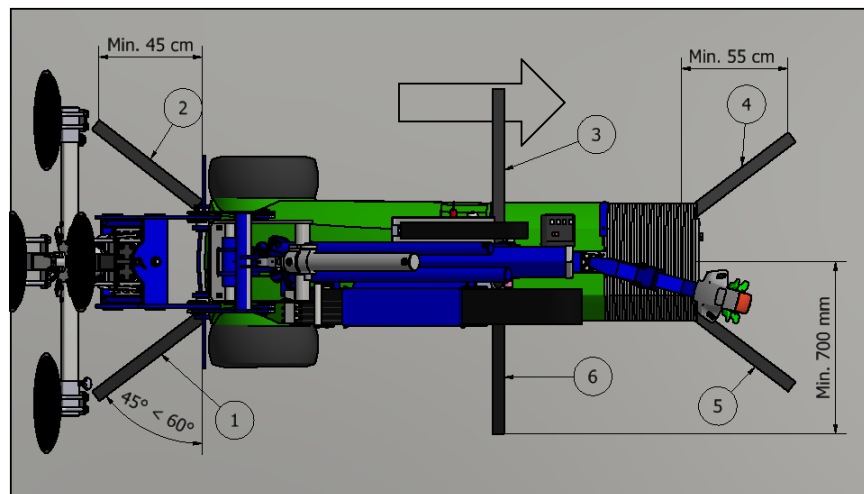

Front (lashing 1 + 2)

In front lashing is done to the welded eyes on bumper placed approximately 225mm above surface. Do not lash over the arm. To prevent this, lash to the sides (as shown) and in an angle of 30-45 degrees to the surface, which gives a distance of approximately 45 cm in front of the machine. Each lashing must be tightened with Tensile load of approximately 5 kN.

Top (lashing 3 + 6)

It is very important to lash "sideways" – to prevent the machine "tilting over" sideways. Lashing should be done using the D-ring tie downs on the side of the boom tower. Lashing must be tightened with Tensile load of approximately 5 kN.

Back end (lashing 4+5)

In back lashings must be parallel to the machine as shown and the eye bolts placed in a distance of approximately 300mm above the surface under counterweights should be used. Lashings must be in an angle to the surface of approximately 30-45 degrees, which gives distance of approximately 55 cm behind the machine. Each lashing must be tightened with Tensile load of approximately 5 kN.

Suggested lashings

We recommend using 3 tonnes lashings. If lashings with larger lashing capacity are used it is important to make sure that these are not tightened with a higher Tensile load than recommended as this can damage the lashing points.

Servicing

Carry out regular checks of the window robot to ensure that it is fault-free when it is to be used.

Check that:

- The mechanical parts of the window robot have not become worn or damaged to such an extent that the safety or performance of the machine is compromised.
- The suction cups of the window robot have not become worn or damaged to such an extent that the safety or performance of the machine is compromised.
- The manoeuvring handle is securely seated and is not damaged.
- All functions on the manoeuvring handle are working correctly.
- The operating panel is not damaged.
- All functions on the operating panel are working correctly.
- The wheels are not damaged or worn to the point that they need replacing.
- There are no leaks from the gearbox, hydraulic pump, cylinders or batteries.
- Vacuum hoses must be inspected for the abrasion and pinching.
- All visible electric cables and hydraulic hoses are intact.

Troubleshooting

If the window robot does not work, check that:

- the ignition key/switch is in the correct position.
- the batteries are not flat.
- the operating arm is not at the top position.

Charging/batteries

General

- Never charge the Winlet 1000 if damage is evident on the battery charger connection cable. This could be fatal!
- Charging must always be done at the designated location, which must be dry and well ventilated. At this location, there may be no sparks from angle grinders, open flames or smoking etc.
- Do not start charging the batteries immediately after the truck has been in use. Allow the batteries to cool first.
- Batteries stored for a prolonged period must have a maintenance charge (be fully charged), to avoid damage to the batteries.

Charging instructions

Charging indicators 230 Volt:

First yellow LED:

Recharging starts with the maximum recharging power. Charging time is determined by how completely the battery is discharged.

Middle yellow LED:

80% battery capacity has been reached. The current will gradually decrease, at the same time the charging voltage will increase and approach the maximum voltage of 28.8V (temperature dependent).













Green LED:

The battery is fully charged, but the charger will maintain a high charging voltage for the next five hours to equalize the charge in the individual cells in the battery. This is done to avoid sulfation of the battery, which is very important in terms of battery life. Therefore, we recommend that the machine be left to charge continuously for at least 15 hours at least once a week. After the 5 hours of equalizing charge, the voltage will drop to 27.5V, again temperature dependent, during the maintenance charge.

Note! See 110 Volt Charging Indicators below.

230V battery charger error messages

If any of these error messages appear, the machine will not charge:

YELLOW	YELLOW	RED/GREEN	DESCRIPTION
			Low battery voltage or no battery connected.
			Battery temperature over 50°C
			Charging time error (timeout), the battery is probably too big for the charger.
			Error in connecting battery, polarity is not correct.

When installing / replacing a new charger

The charger has a built-in temperature sensor so that the charger can compensate for the temperature of the batteries. The sensor is integrated in the charger's minus charging cable (black cable), so this cable must not be shortened, but must be mounted as it is directly on the battery.

Charging indicators 110 Volt:

Yellow LED:

Recharging starts with the maximum recharging power. Charging time is determined by how completely the battery is discharged.









When 80% battery capacity is reached, the charging current will gradually decrease. At the same time the charging voltage will increase and approach the maximum voltage of 28.8V.

Green LED:

The battery is fully charged, but the charger will maintain a high charging voltage for the next five hours to equalize the charge in the individual cells in the battery. This is done to avoid sulfation of the battery, which is very important in terms of battery life. Therefore, we recommend that the machine be left to charge continuously for at least 15 hours at least once a week. After the 5 hours of equalizing charge, the voltage will drop to 27.5V, during the maintenance charge.

110V battery charger error messages

If any of these error messages appear, the machine will not charge:

YELLOW	GREEN	RED	DESCRIPTION
			Low battery voltage or no battery connected.
			Charging time error (timeout), the battery is probably too big for the charger.
			Error in connecting battery, polarity is not correct.

Charging

- Always charge after use.
- Turn the Winlet 1000 off with the ignition key/at the off-button.
- Connect an earthed plug with voltage 230 V (110V). Charging time is approximately 12 hours, if the batteries are completely flat.

Wheel attachment

- The wheel bolts are tightened with a torque of 225Nm.

Service/maintenance

General

The Winlet 1000 is designed to cope with the demands and the conditions on construction sites, but its service life and safety can be reduced considerably if the stated service/maintenance items are not complied with.

All mechanical joints must be checked at regular intervals to ensure that no components have worked loose. In general, special attention is required after the initial hours of operation when the machine is brand-new, as well as after the machine has been taken apart/any repairs.

Servicing by specialist personnel

As a minimum requirement, a full overhaul must be carried out by specialist personnel every 12 calendar months. Contact GMV A/S for further information.

Cleaning

Clean the machine regularly with a damp sponge, brush or vacuum cleaner.

Important! Do not wash the machine with running water, as this could destroy truck components.

Lubrication

The Winlet 1000 is primarily constructed with maintenance-free bearings in all moving parts. All these parts must be kept free of dirt, but lubrication is not required. This means the machine should only be lubricated with grease at the bearing assemblies as required:

Extension arm

Should not normally be lubricated during everyday use, but only on annual inspection, at least every 12 months. It may be necessary to lubricate the bearing if the movements of the extension arm become sluggish. This is done by removing the holder for the slide block (see graphic) and greasing the point where the sliding blocks are mounted at the front of the extension arm. This must also be checked in the annual inspection and possibly replaced in the case of obvious wear.

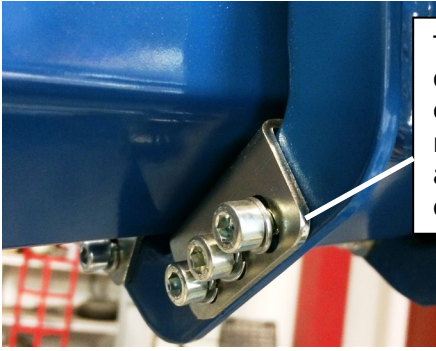

The holder should be dismantled at the annual check, with if necessary replacement of wear pads and holders if obvious signs of wear are present.

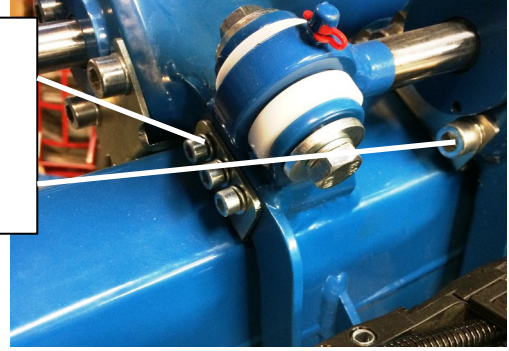

Overhaul

The machine is equipped with grease nipples - for checking purposes and topping up with grease at each overhaul (at least every 12 months)

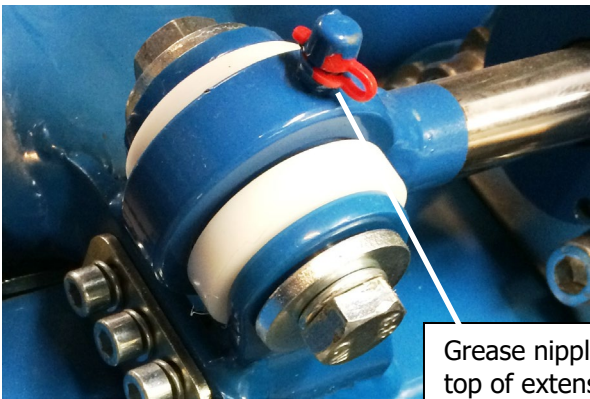

Grease nipples on top of extension cylinder.



Grease nipples in precision hoist on both sides.

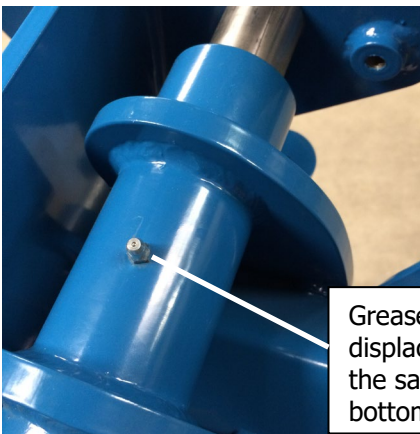

Grease nipples in later displacement unit are the same at top and bottom.

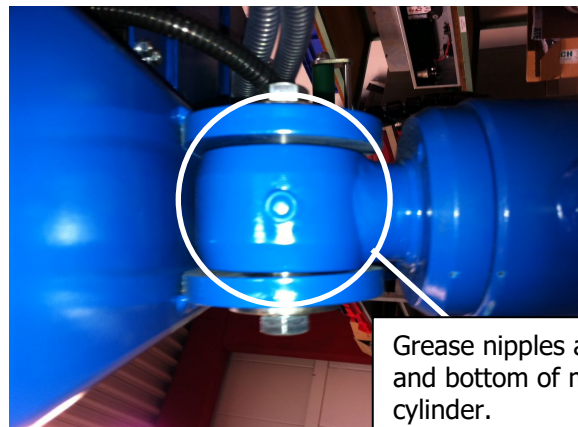

Grease nipples at top and bottom of main cylinder.

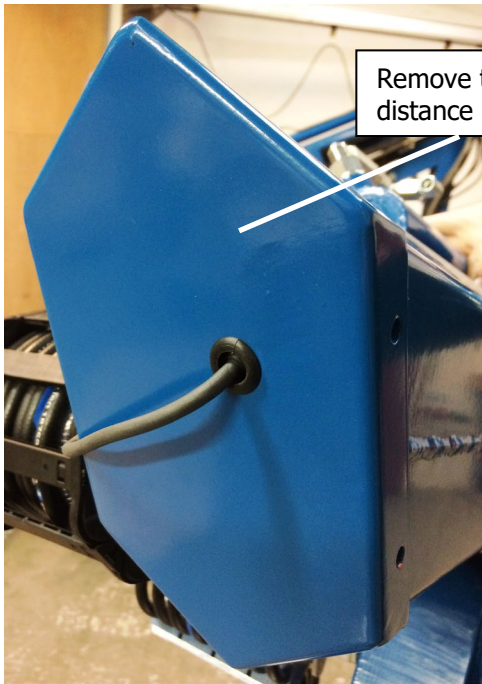

Remove the back cover to access the angle and distance indicator.

Important!

Remember that all prolonged and repeated contact with oils and lubricants constitutes a risk to health; whenever necessary, wear protective gloves and goggles when implementing the points below.

Maintenance of the hydraulic system

- Change the oil after every 1500 operating hours or at least once a year (oil type Gulf Harmony ZF HVI 32 or similar).

Maintenance of the vacuum system

- The vacuum pump contains wearing parts. If the pump cannot achieve a vacuum level of min. 70% (-70 kPa), it must be replaced or serviced by qualified personnel.
- Do not dismantle the vacuum pump while it is under warranty – this would invalidate the warranty.
- The vacuum system is fitted with a filter. The filter is located in the machine's motor compartment, beside the two vacuum tanks. The filter must be cleaned at appropriate intervals, depending very much on how clean and particle-free the items being lifted are.
- The window robot's vacuum system must have all the hose clamps re-tightened as required.
Important! The screwed-on fittings must not be re-tightened because they are sealed with floating, self-hardening thread sealant. Re-tightening them could give rise to a risk of leakage. If they are accidentally re-tightened, the error must be rectified immediately by re-sealing the fittings.

Drive shaft lubrication/maintenance

- Do not open the drive shaft/motor while under warranty – opening it will invalidate the warranty.
- Service the carbon brushes after every 500 hours of operation – if the length is less than 12 mm, they should be replaced.
- Service the brake function after every 500 hours of operation – the air gap must be 0.3–0.4mm.
- Check the oil level after every 500 operating hours.
- Service seals and re-tighten bolts after every 1000 operating hours.
- Change the oil after every 1500 operating hours or at least once a year (oil type SAE80W90 GL3).

Specifications:	
Max. load	1000 kg
Width	890 mm
External length	2100 mm
Intrinsic weight	1850 kg
Min. extension	600 mm
Max. extension	2500 mm
Max. height of centre lifting yoke	4,100 mm
Lateral displacement	75 mm
Precision hoist in tower	200 mm
Rotation	180 degrees
Suction cups	4 x ø410 mm
Motor	24 Volt
Speed – min./max.	0–6 km/h
Raising-lowering function	Electric-hydraulic
Battery	24 Volt - 2 x 150 Ah
Charging – integrated charger	230V(110v)

Sound pressure level

The sound pressure level of the machine has been tested during driving with the machine's driving gear, with the machine's vacuum pump running simultaneously. The following values were measured:

A-weighted sound pressure level: Below 70 dB(A)

C-weighted maximum sound pressure level: Below 63 Pa (130 dB compared to 20 µ Pa).

CE – EU Declaration of conformity

Manufacturer

Company name: GMV A/S
Address: Industriparken 1
Post code: 7182 Bredsten, Denmark
Tel.: +45 7573 8247

Responsible for the technical dossier

Authorised to prepare the technical dossier:

Jesper Faurskov
GMV A/S
Industriparken 1
7182 Bredsten, Denmark

hereby declares that

Machine

Name: Winlet
Type: 1000-H
Machine no.: 113052

- a) conforms to the following Directive:
 - i. Machinery Directive 2006/42/EC
- b) Manufactured in accordance with the following national/international standards and technical specifications:
 - i. The Danish Working Environment Authority, "anvisninger om tekniske hjælpemidler" (instructions concerning technical aids")
 - ii. The Danish Working Environment Authority, "meddelelser om tekniske hjælpemidler" (notifications concerning technical aids")
 - iii. The Danish Working Environment Authority, "vejledninger om tekniske hjælpemidler" (guidelines concerning technical aids")
- c) Manufactured in partial accord with the following harmonised standards:
 - i. EN 13155-2003

Signature

Name: Jesper P. Faurskov
Title: Director
Company: GMV A/S
Date:

Signature:

